

YARD DRAIN THROUGH CURB (REQUIRES CITY PERMIT)

N.T.S.

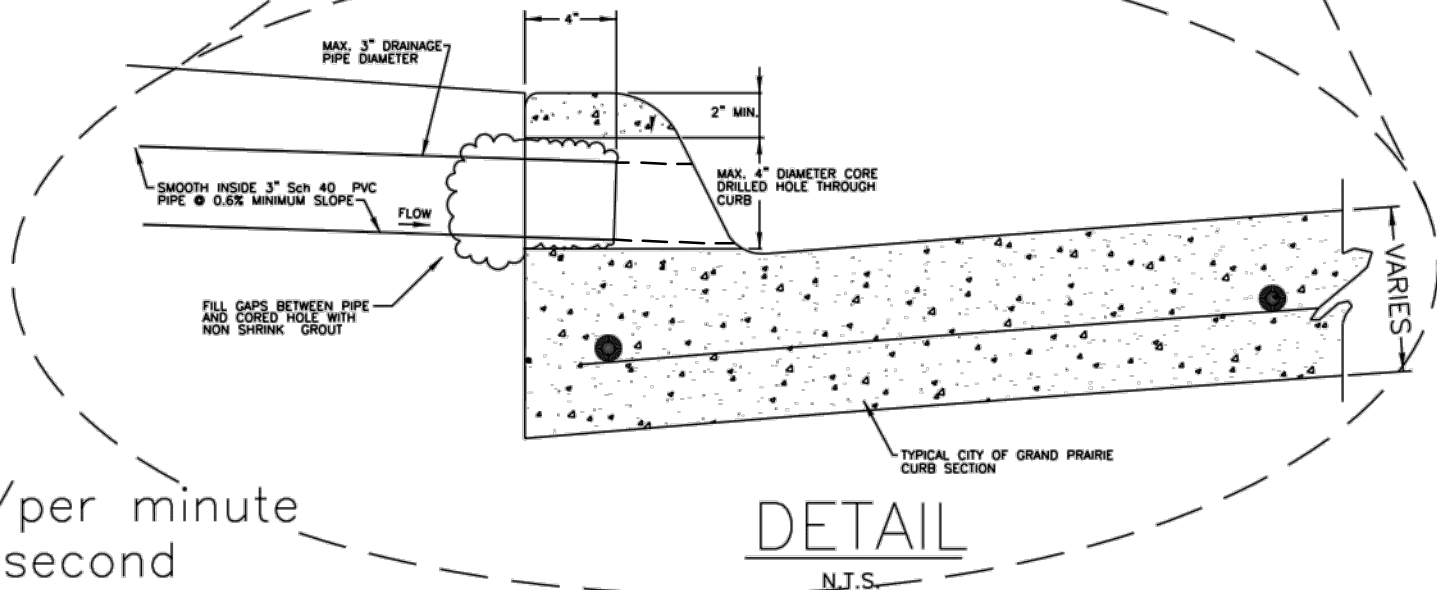

3"Ø PVC PIPE

@ 0.6%

$n=0.011$

$Q_{cap}=0.08$ cfs

$Q_{cap}=36$ gallons/per minute

$V=1.65$ feet per second

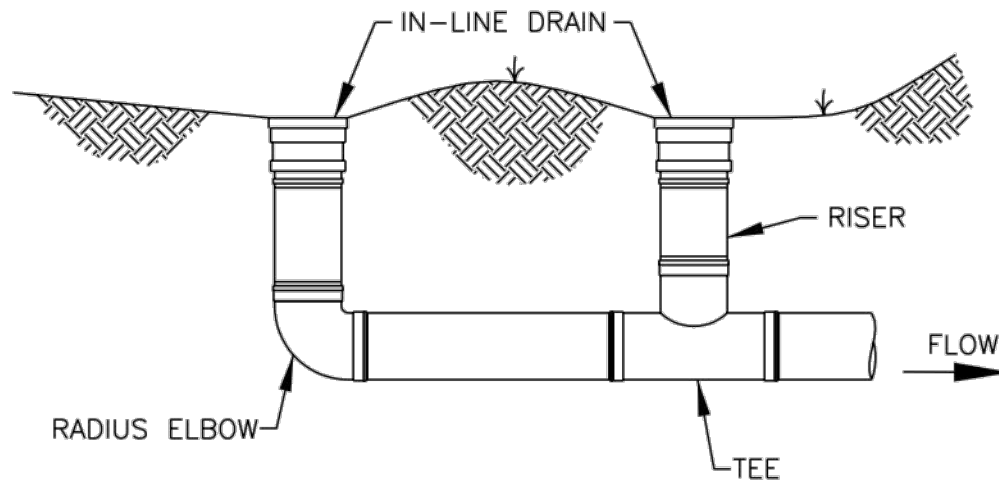

TYPICAL INLINE DRAIN INSTALLATION

N.T.S.

Engineered Surface Drainage Products

(REQUIRES CITY PERMIT)

GENERAL

PVC surface drainage inlets shall be of the inline drain type. The cast iron grates for each of these fittings are to be considered an integral part of the surface drainage inlet and shall be furnished by the same manufacturer. The surface drainage inlets shall be as manufactured by Nyloplast America, Inc., or prior approved equal.

MATERIALS

The inline drain required for this contract shall be manufactured from PVC pipe stock, utilizing a thermo-molding process to reform the pipe stock to the furnished configuration. The drainage pipe connection stubs shall be manufactured from PVC pipe stock and formed to provide a watertight connection with the specified pipe system. This joint tightness shall conform to ASTM D3212 for joints for drain and sewer plastic pipe using flexible elastomeric seals. The pipe bell spigot shall be joined to the inline drain body by use of a swage mechanical joint. The pipe stock used to manufacture the inline drain body and pipe bell spigot of the surface drainage inlets shall meet the mechanical property requirements for fabricated fittings as described by ASTM D3034, Standard for Sewer PVC Pipe and Fittings; ASTM F1336, Standard for PVC Gasketed Sewer Fittings.

The grates furnished for all surface drainage inlets shall be ductile iron grates for sizes 8", 10" & 12" shall be made specifically for each fitting so as to provide a round bottom flange that closely matches the diameter of the surface drainage inlet. Grates for inline drains shall be capable of supporting H-20 wheel loading for heavy-duty traffic or H-10 loading for pedestrian traffic. 12" will be hinged to the frame using pins. Metal used in the manufacture of the castings shall conform to ASTM A-48-83 Class 30B for cast iron frames. Grates shall be provided painted black.

INSTALLATION

The specified PVC surface drainage inlet shall be installed using conventional flexible pipe backfill materials and procedures. The backfill material shall be crushed stone or other granular material meeting the requirements of class 1 or 2 material as defined in ASTM D2321. The surface drainage inlets shall be bedded and back-filled uniformly in accordance with ASTM D2321. For H-20 Load rated installations, an 8" to 10" thick concrete ring will be poured under the grate and frame as recommended by details provided to the manufacturer.